



*An Online PDH Course
brought to you by
CEDengineering.com*

Power Quality Measurements

Essential Theory

Course No: E04-035

Credit: 4 PDH

Velimir Lackovic, Char. Eng.



Continuing Education and Development, Inc.

P: (877) 322-5800
info@cedengineering.com

www.cedengineering.com

WHY DO WE MEASURE POWER QUALITY?

The decline in quality of power is a big issue due to increase in the usage of power electronics that uses inverters, an increase of unbalanced loads like large furnaces or rectifiers, and typically complex power distribution due to an increment in power network interconnections for new energy plants, etc. Inadequate power quality induces potential problems in receptacle/transmission devices and electronic apparatus malfunctions. For instance, harmonics is known to produce burn-out reactors and bad noise in capacitors. Moreover, impulse noise and voltage drops block control elements that are dependent on a computer.

Power supply network issues that are induced by inadequate power quality are a frequent issue for both electric power providers and consumers. Nevertheless, it is not simple to tell if the source of inadequate power supply quality is at the provider's side or the consumer's system. Depending on this arrangement, power quality measurement is required to know the actual source of power quality issues as well as to treat and assess for efficient countermeasures.

POWER QUALITY PARAMETERS AND EVENTS

The power quality factors are the items needed for examining and assessing power problems. By quantifying the power quality factors, user can obtain a complete understanding of the power quality profile. Threshold quantities are set on the power quality instrument to measure the "fault value" or "fault waveform" for the power quality factors. Afterwards, the power quality analyser describes "phenomenon" when the input surpasses the previously set thresholds. (Real problem does not always happen at event sensing because thresholds are predetermined by anticipating certain fault figures.)

The raising application of devices and loads with a non-linear current–voltage features

and/or operating features which are not steady over time, has headed to an raise in electrical system disturbances in electrical power supply of public power supply and industrial electrical networks. In parallel with the evolution of suited regulations and recommendations for the resolution of limits and compatibility levels, assessment methods and devices are being built which allow the relevant measured figures for system disturbances to be developed. The following measures are of special interest:

- Voltage fluctuations
- Flickers
- Transient over-voltages
- Voltage unbalance
- Harmonics
- Inter-harmonics

Figure 1 presents these measures relative to the frequency range to which the assessed measures are to be attributed. The magnitudes at which the individual measures happen are also provided. It is not feasible to provide an exact statement in relation to the frequency range for voltage fluctuations. The magnitudes are within a range of a several percentage points of the R.M.S. figure. For flickers, the frequency is in a range from a several millihertz up to around 35 Hz. The magnitudes are in the range of up to a several percentage points.

For harmonics, the spectrum is typically looked at up to a frequency of 2.5 kHz. The magnitudes of the voltage are also in the order of a several percentage points. For current harmonics the figures can be in the amplitude of the fundamental element or even bigger. Voltage unbalances are typically in the order of 1% to 2% and are in relation to the fundamental element.

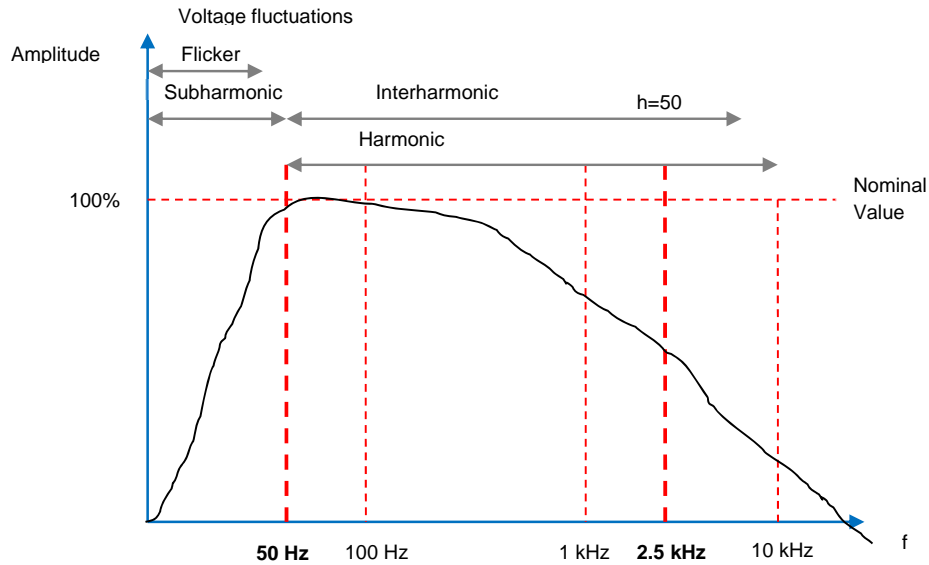

Figure 1. Frequency range of disruptions

FREQUENCY FLUCTUATION

Frequency fluctuation happens due to a variation of effective power balance between generation and load, or an excessive gain or reduction of the load. Changing rotation speeds of synchronous electrical machines, the most typical generator type, utilized in electrical power systems, may be the reason of frequency fluctuations. Typical frequency fluctuation is shown in Figure 2.

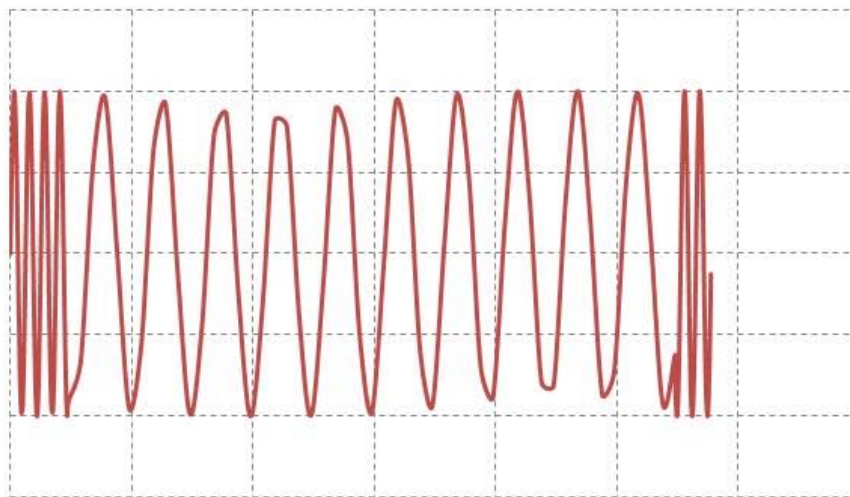

Figure 2. Frequency fluctuation

VOLTAGE SWELL (SURGE)

This is the instant voltage raise induced by lightning strikes, switching on/off a power supply circuit, capacitor bank switching, line-earth short circuit, or dropping a heavy load, etc. It may also happen due to the electrical network connection of a new generation source (solar, wind power, etc.). A fast raise in voltage may interrupt or reset the power supply of equipment. Typical voltage swell is shown in Figure 3.

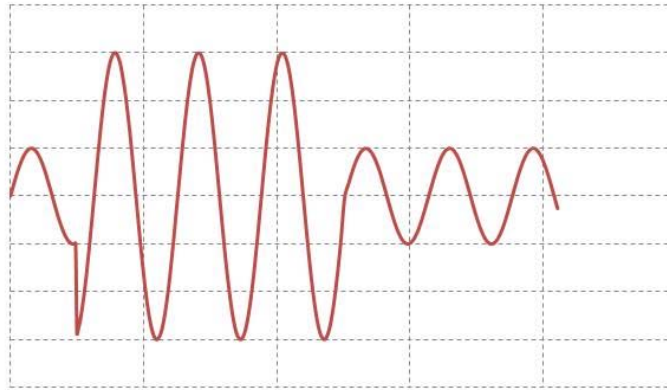

Figure 3. Voltage surge

TRANSIENT OVERVOLTAGE (IMPULSE)

This is the voltage variation caused by a lightning strike, contact issue and closing of a circuit breaker/protection relay. It is usually a quick change and involves of high peak voltage. Damage to device's power supply or reset function typically happens near the production point due to its high voltage. Typical transient overvoltage is shown in Figure 4.

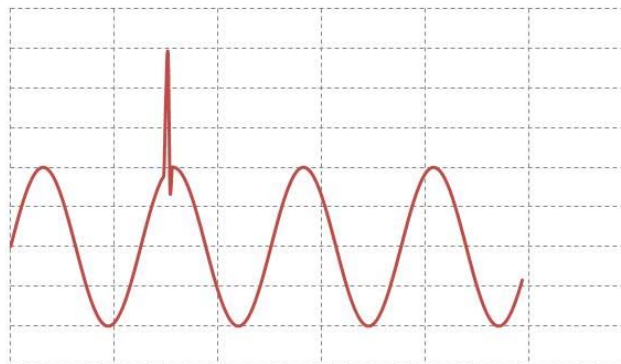

Figure 4. Transient overvoltage

FLICKER

Flicker is a sporadically duplicated voltage fluctuation generated by a furnace, arc welding or thyristor controlled load. It may get lights to flicker and devices to malfunction. When the flicker value is big, majority of the people feel awkward because of the flickering lights.

VOLTAGE DIP (SAG)

Majority of the voltage sags are generated by the natural cause like thunder and lightning. It is presented by an instant voltage drop generated by the cutting off of the electrical supply circuit due to a short circuit to the earth or big inrush current generation when starting a large motor, etc. Due to the voltage drop, it may generate a stop or reset of device, switching off lighting, speed variation or stop of motor, and synchronization error of synchronous machines. Typical voltage dip is shown in Figure 5.

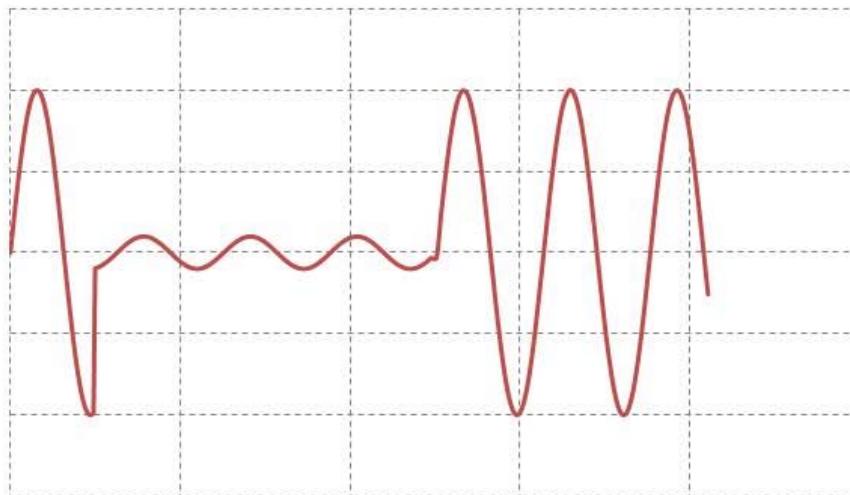

Figure 5. Voltage dip

INTERRUPTION

This is a power outage over an instant, short or prolonged period. It is generated by events such as lightning strikes or tripping of the breaker because of a short-circuit current. Lately, UPS devices are frequently used to save PCs, but this device type may

also induce a stop or reset of device. Typical interruption is shown in Figure 6.

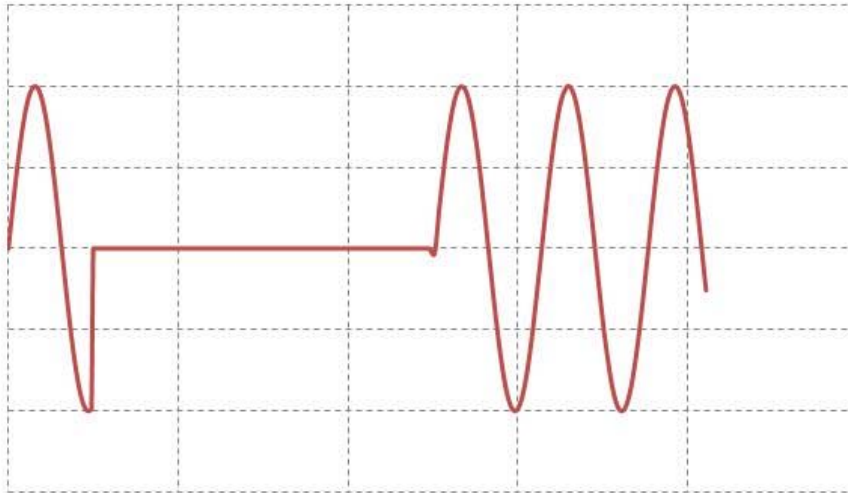

Figure 6. Voltage interruption

HARMONICS

Harmonics are caused by semi-conductor control equipment in the power supply of device as a result of deformed voltage and current waveforms. When the harmonic portion is high, it may introduce severe problems such as overheating or noise in motors or transformers, break down reactors in phase compensation capacitors, etc.

HIGH-ORDER HARMONIC COMPONENT

This is a noise component greater than several kHz made by the semi-conductor control equipment in the power supply of device, and may hold different frequency elements. High-order harmonic elements may damage the power supply of device, reset device or bring in abnormal noise in device such as TVs or radios.

INTER-HARMONICS

Inter-harmonics are caused by a voltage/current waveform disruption made by an electronic frequency converter, cycle converter, inductive motor, welder or arc furnace, etc., and comprises of non-integer orders of the fundamental frequency. Inter-harmonics may make damage, malfunction or deterioration of devices due to the zero-

cross shift of the voltage wave.

UNBALANCE

System unbalance is made by the rise or reduction of load connected to each line, partial running device, voltage/current waveform twisting, voltage drop, or reverse phase voltage, etc. The event may induce revolution faults, increased noise, and less torque in a motor. Moreover, it may generate a breaker to trip, transformers to heat, or a loss increase in a capacitor smoothing rectifier, etc. Typical unbalance is presented in Figure 7.

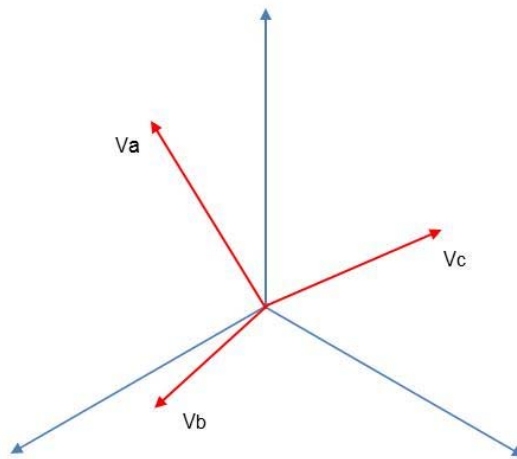

Figure 7. Voltage unbalance

INRUSH CURRENT

This is an instant high current flowing at the time device is switched on. Inrush current may cause protection relays to malfunction, circuit breakers to switch off, impact on the rectifier, unstable power supply voltage, and/or device to malfunction or reset. Typical inrush current is shown in Figure 8.

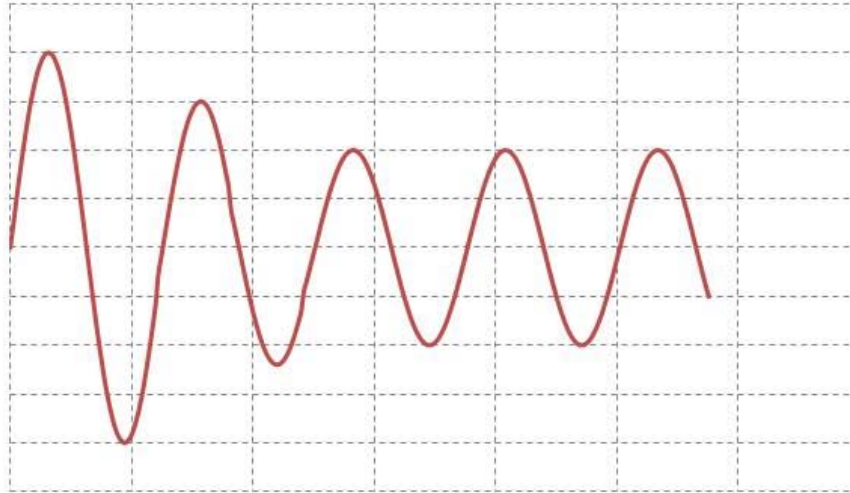

Figure 8. Inrush current

SAMPLING SYSTEMS - GENERAL CHARACTERISTICS

With the introduction of modern digital devices, devices functioning in the time domain have been repelled. The equipment used for the power quality assessment has quickly improved. Computers have become powerful and sophisticated, capable to complete a growing number of operations per time unit. Digital signal processing is also approaching new fields in relation to sampling frequency and magnitude resolution.

The two measures crucial for digital signal assessment are the sampling frequency and magnitude resolution. Figure 9 presents how an analogue measured signal is transferred to a continuous sampling sequence by sampling in the time range. If the magnitude is then transferred to discrete amplitude figures, using an analogue-digital converter, this generates a value sequence which can be treated by a computer or digital signal processor.

BASIC ARRANGEMENT OF A DIGITAL MEASURING DEVICE

The basic working principle of a digital measuring device comprises of several elements as presented in Figure 10. The assessed signal is uncoupled by an input adapter.

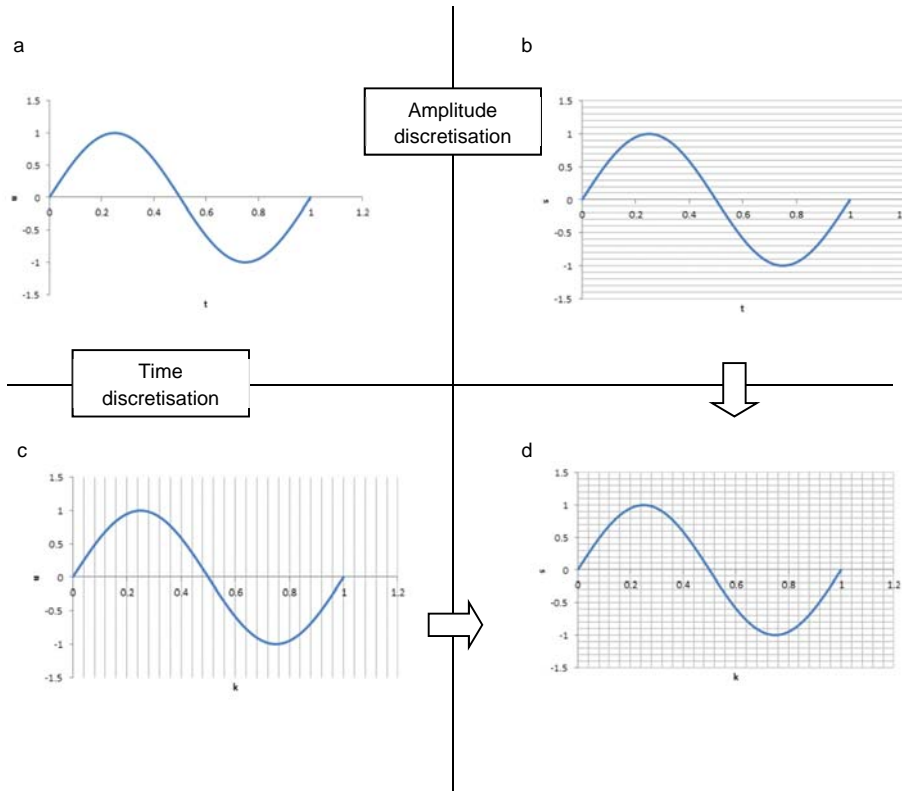

Figure 9. Magnitude and time discretisation (a) uninterrupted in time/continuous in range (b)uninterrupted in time/discrete in range (c) discrete in time/continuous in range (d) discrete in time/discrete in range

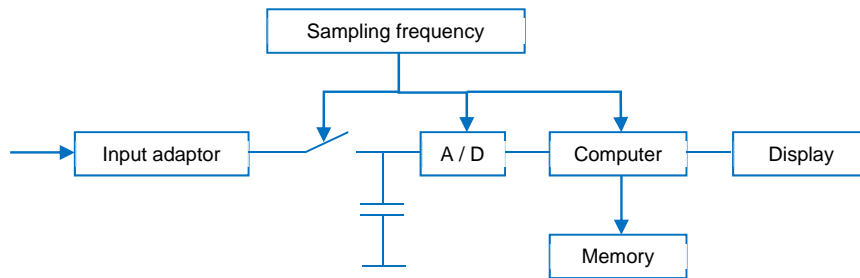

Figure 10. General block-structure of digital measurement systems

This arrangement fixes the frequency range of the measuring device to the operating range and saves the electrically-sensitive electronics. The frequency band is fixed by a low-pass filter, i.e. an antialiasing filter. An A/D converter transfers the continuous analogue signal to a sampling sequence which is discrete in relation to both magnitude and values. The sample and hold devices are placed between the input adaptor and

converter. The function of this element is to keep measured signal constant for the period of the A/D transfer.

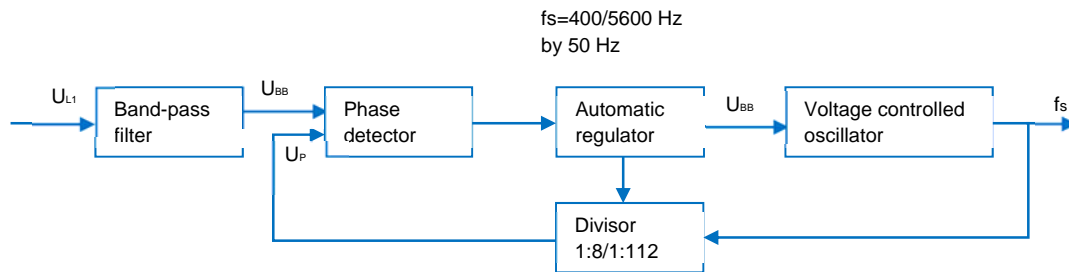

Figure 11. Phase-locked-loop element (PLL)

The sampling sequence given by the A/D converter is then additionally refined by the arithmetic logic unit. This is a microcontroller, a signal processor or a complex processor system. This arithmetic logic element also checks the display and any memory elements. The sampling frequency and other control signals for the arithmetic logic element, and also for any display, are produced by a controller. This can comprise of a crystal generator with matching divider stages or a phase-locked-loop (PLL) arrangement. The production of sampling and control frequencies utilizing a crystal generator generates sampling sequences where the sampling impulses constantly happen at the same intervals. This implies that time sections from a measured sampling sequence can be predetermined. This method of sampling frequency production is applied on oscilloscopes and other recording devices, such as transient recorders. Nevertheless, if a sampling sequence is needed which is in a numerically-fixed relation to a predominant frequency part in an assessed signal, and if the frequency of this signal is subject to certain variations, only a PLL can then be looked at for production of the sampling frequency. The device arrangement is presented in Figure 11.

It should be noted that the frequency in the 50 Hz electrical grid system can vary within the 49.95 Hz to 50.05 Hz range as shown in Figure 12. A direct assignment of evaluated signals to particular time points is no longer feasible where a PLL is applied. Either the frequency of the PLL or the corresponding equivalent numerical quantity must be kept. The timing can then be rebuilt using these quantities. The PLL is generally applied for harmonics analyzers and flicker meters.

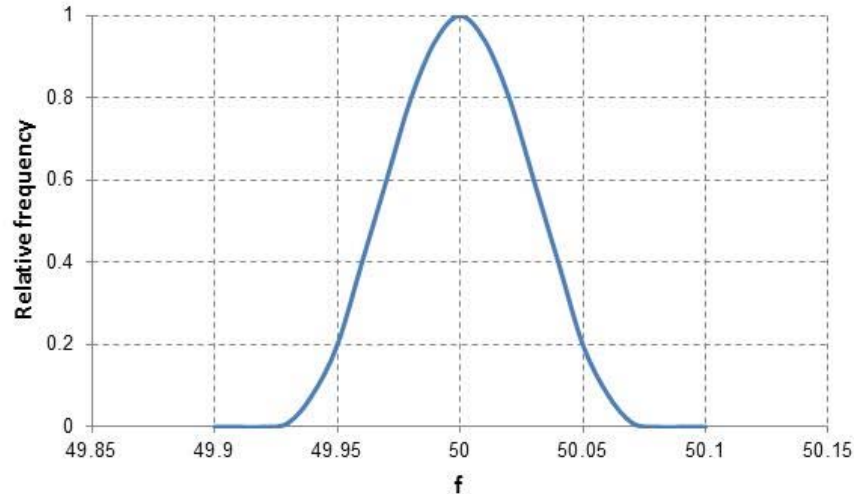

Figure 12. Relative frequency of 50 Hz network frequency

TRANSIENT RECORDERS

Measurement devices or transient recorders are applied to assess voltage variations. The voltage variations must then be assessed using the time course of the subjected voltage. The method of recording devices for measuring voltage variations is presented in Figure 13. The principal characteristics of a transient recorder are its magnitude resolution, its sampling frequency and its memory capacity. The magnitude resolution is from 12-bit to 14-bit (4.096 levels up to 16.384 levels). The sampling frequencies go from around 10 kHz to 100 kHz. Transient recorders with sampling frequencies of a several megahertz are available for measuring very fast signals, e.g. transient over-voltages. These devices typically have magnitude resolution of between 8 bits and 10 bits (256 levels up to 1.024 levels). The measured signals can be also printed. Program packages or tabular calculation software can be applied for additional assessment of the recorded values using a computer.

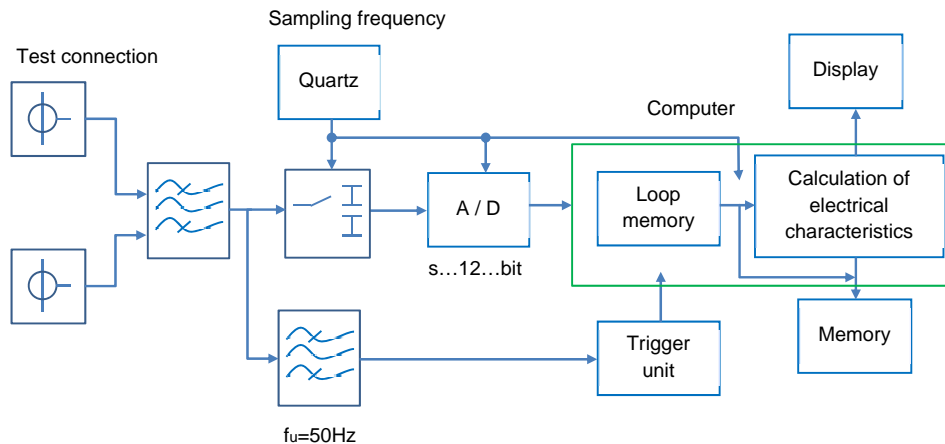

Figure 13. Typical arrangement of a transient recorder

HARMONICS ANALYSERS

Different kinds of recording devices have long been used for assessing harmonics. Harmonics analysers can, for example, be made on the basis of selective filters matched with R.M.S. quantity measurement. Such devices are not frequently used today. Because of the technical advancements in computer industry, devices comprising sampling systems and which compute harmonic portions applying Fourier transformation, or discrete Fourier transformation (DFT), are more typically applied. A harmonics analyser which finds out the harmonic portions using Fourier transformation comprises of the following elements:

- Measured signal coupling/amplifier,
- Antialiasing filter,
- Sample and hold elements,
- Multiplexer,
- A/D converter
- Computer element,
- Display element,
- Storage element,
- Component for producing the sampling frequency and a controller.

The listed elements are principally arranged as presented in Figure 14. The recorded

signal can be input either galvanically separated or galvanically coupled. Afterwards it is amplified for the individual recording ranges for the best control of the A/D converter results. These elements can also compensate for the fundamental component. The recorded signals are then transferred to the antialiasing filter and band-fixed. After this initial process, the signals are then transferred to the sample and hold components. The elements mentioned up to now are given for each recording channel. Depending on the design of the device, the recorded signals of the separate channels are either transferred via a multiplexer to a central A/D converter, or each recording channel may have its own converter. A/D converters in typically have a resolution of 12 to 16 bits (4,096 to 65,536 quantisation levels). The digitalized recorded values are transferred to the computer device where they are assessed. From here, the recording results are transferred to the display, statistically treated and stored as required.

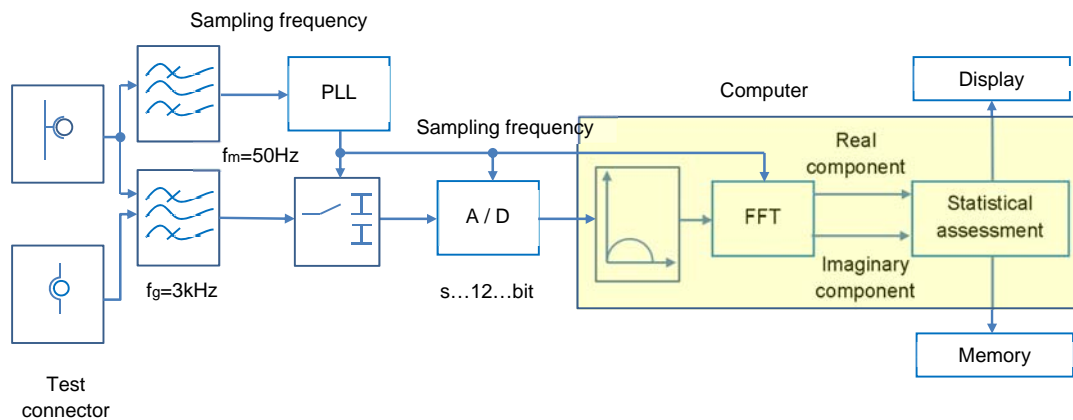

Figure 14. Typical arrangement of a measurement system for harmonics

COMBINATION DEVICES

Different devices can be utilized for measuring and assessing the voltage quality and checking the system disruptions, depending on the individual aspects to be looked at. Table 1 presents an overview of the assignment of devices to the individual aspects of the checking of the voltage quality by measurement.

Because of the great degree of integration that can be accomplished with modern technology, recording devices are available that are a mix of transient recorders,

harmonics analysers, flicker meters and oscilloscopes. These devices can complete the individual recording functions simultaneously. Moreover, these devices are equipped with special assessment functions and adequate software to check the recordings.

Table 1 Assignment of recording devices

Measuring instrument	Voltage fluctuation	Flicker	Unbalance	Harmonics	Inter-harmonics	Measured time period	Accuracy	Complex evaluation	
								Present	Possible
Mechanical	0	-				Up to days	0	No	No
Electronic	+	-				Up to days	0 to +	No	Yes
Storage oscilloscope	+	-		-		Short	0 to +	No	Yes
Transient recorder	+	0	+	0	0	Short	0 to +		
Spectrum analyser									
Laboratory instruments			0	+		Short	+	Conditional	Yes
Hand held instruments			-	0		Up to days	- to +	Conditional	Conditional
Special instruments			+	+	+	Up to weeks	+	Yes	Yes
Flicker meter	?	+				Up to weeks	+	Yes	/

RECORDED VALUE PROCESSING - STATISTICAL TECHNIQUES

The instant values of a characteristic are not assessed directly when analyzing system disruptions. Recording findings are analyzed from a statistical point of view relative to compatibility levels. Overshoots of compatibility levels are allowed for short time durations. This is applicable, for disturbed operating situations and switching procedures. Additional aspects for utilization of recording devices are: applicability for field use, simplicity of operation, data exchange, and possibility for calibration.

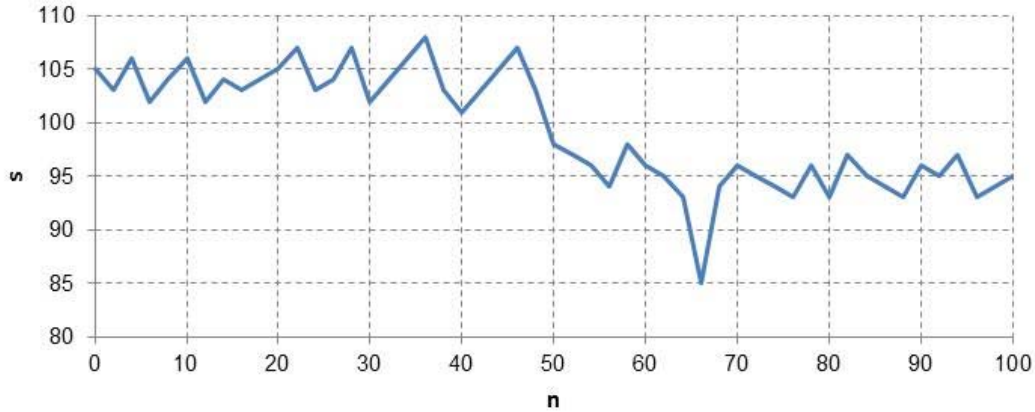

Figure 15 Sequence of recorded values $s[n]$

Because of the issue that recordings of system disruptions and voltage quality must typically extend over a prolonged time period in order to enable an analysis, the usefulness of individual recording results is limited. This means that a high number of individual findings have to be checked and analyzed. For this reason, a series of simple techniques which additionally process the real recording results for various needs is utilized to assess and compress measurement findings.

The following processing technique for a time sequence $s(n)$ is regarded very important. The time sequence can, show each recorded value. At this point it is irrelevant if this is a voltage or a harmonic portion. If one studies the example time sequence $s(n)$ presented in Figure 15, the mean-value production is a frequently-used technique for smoothing the recorded signal. It can be in the form of simple mean-value production. In addition to this form, techniques are also applied whereby the root mean square value or geometric mean value are found. The R.M.S. values of voltage and current are computed using the root mean square value. Arithmetical mean value:

$$\bar{S}_A = \frac{1}{N} \sum_{t=1}^N \quad (1)$$

Root mean square value:

$$\bar{S}_Q = \sqrt{\frac{1}{N} \sum_{t=1}^N} \quad (2)$$

Cubic mean value:

$$\overline{S}_K = \sqrt[3]{\frac{1}{N} \sum_{t=1}^N} \quad (3)$$

The determining factor in the question of if the data volume decreases during mean value generation or keeps constant is if the mean values are formed as 'sliding' or 'non-sliding'. In the situation of sliding mean value generation the volume of information keeps constant. This means that for each new figure the first value of the considered interval is neglected and a new one added. If the mean value finding is non-sliding, the accomplished decrease in the volume of information is dependent on the length of the mean-value generation interval. In the situation of mean values which are found non-sliding, the signal course received depends on the starting point of the mean-value generation. Mean-value generation polishes a recorded signal. An additional step in depicting a recorded value sequence is the relative frequency. The relative frequency presents how many recorded values, relative to the overall number of recorded values, of a sequence lie within a specific magnitude class. With the relative frequency, the time relationship of the particular information of the output sequence is lost while sequences of any length can be focused in a limited space. The area in which the magnitude figures and their distribution are placed can be easily seen.

The recorded values can also be identified by finding out the relative cumulative frequency. This is found out from the relative frequency by the addition of all the relative frequencies which are higher than, or equal to, the considered magnitude value. Figure 16 presents the characteristic of the relative cumulative frequency of the magnitude of the $s(n)$ time sequence.

The form presented in Figure 17 is typically selected for system disruptions. From the course of the relative cumulative frequency, the magnitudes for different time durations can be determined, relative to the complete measurement time period. The 95% cumulative frequency value is utilized to determine the compatibility level of harmonics. This implies that relative to the considered interval, the corresponding recorded value of the voltage harmonic content has to lie below the compatibility level for 95% of the checked interval. The measurement time period is to be linked to the load cycle and hence its duration cannot be anticipated. Figure 18 is an example of the course of the

cumulative frequency of a specific measure (fundamental component). The 95% and the 99% cumulative frequency figures are entered.

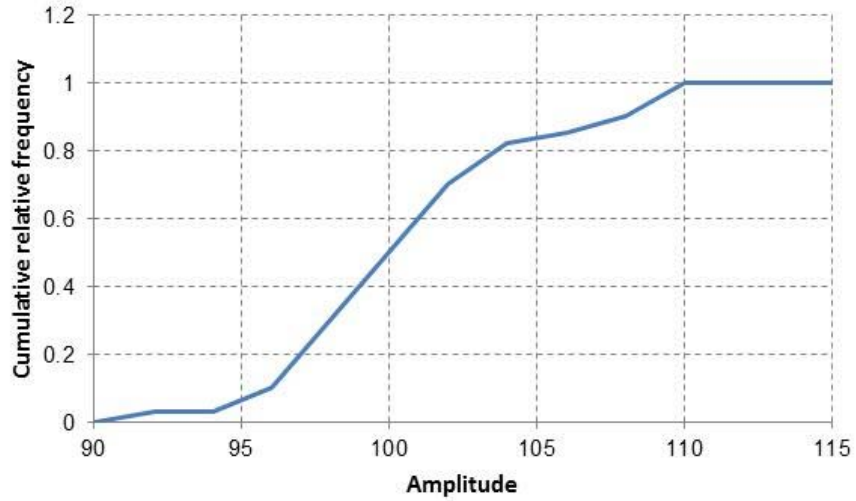

Figure 16. Cumulative relative frequency (normal representation)

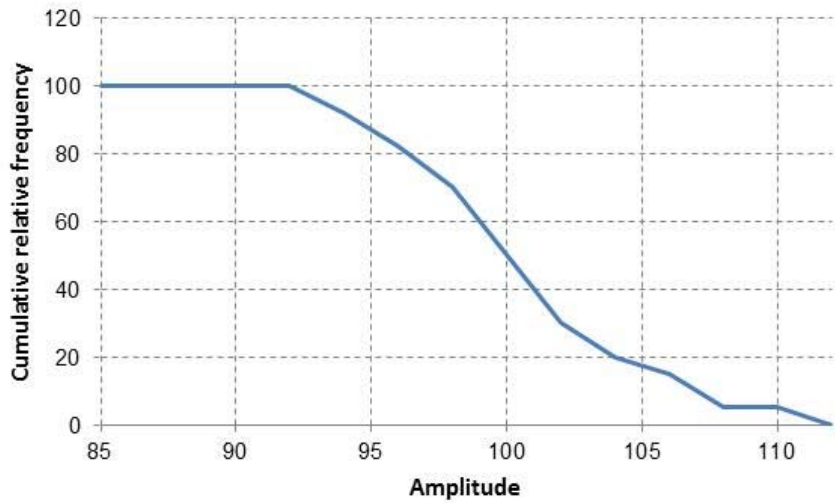

Figure 5.13. Cumulative relative frequency (representation for disruptions)

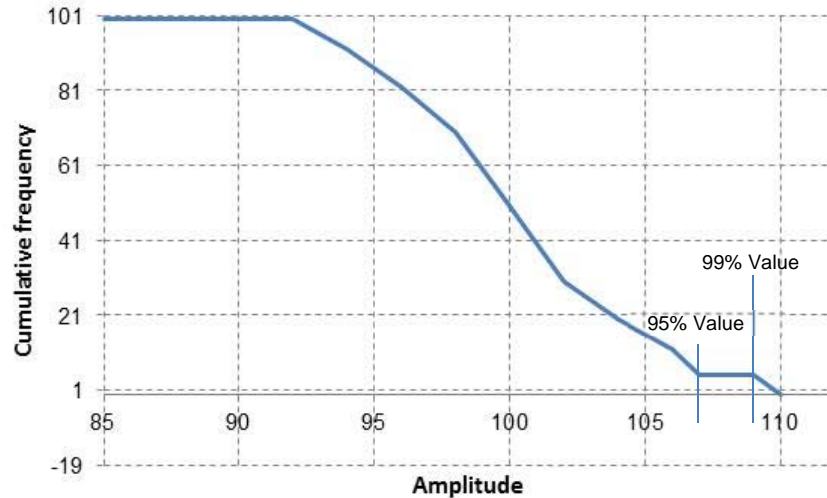

Figure 18. Example for cumulative frequency of a characteristic measure

RECORDING AND EVALUATION TECHNIQUES

To organize up a wide base for productive recordings needs a wide variety of recording techniques, as well as suited ways of assessment and organising the different findings of short- and long-term recordings. An overview of the findings of the direct physical recordings, mixed with the sequential quantities deduced from them, gives a variety of individual items of data with different content. These comprise the following quantities:

- Voltage and current in the form of the instant figure. These figures can be recorded directly and are kept in time sequence form.
- Voltage and current R.M.S. figure. These figures are computed from the particular instant figures.
- Active, reactive and apparent power and power factor. These figures are computed either from the R.M.S. figures or from the instant figures.
- Harmonic elements for current and voltage according to quantity and phase.
- Fourier transformation is applied for the computation. Sequential quantities can be computed on the basis of these figures.
- Angle of the harmonic elements relative to the fundamental component
- Angle between voltage and current of the harmonic components
- Harmonic active power and harmonic reactive power
- Total harmonic distortion factor (THD)

- Weighted harmonic distortion for inductances
- Weighted harmonic distortion for capacitances

PARTIAL WEIGHTED HARMONIC DISRUPTION

Partial weighted harmonic disruption can be quantified with the following:

- Short-term flicker distortion values that are computed from the voltage instant figures utilizing the flicker computation algorithm.
- Long-term flicker values that are computed from the short-term flicker distortion figures.
- Degree of unbalance of voltage and current that are computed from the fundamental components of voltage and current.

In addition to these values or their time sequences, it has to be possible to check the relative cumulative frequency figures from the special time sequences for all figures which are being checked with regard to compatibility levels. In this situation it is beneficial if the frequency limit can be freely specified. In any situation, the quantities of the 95% cumulative frequency have to be checked because the compatibility levels refer to this figure. To adequately check the 95% cumulative frequency figures relative to compatibility levels, the recording time period has to be selected in advance so that it relates to a load cycle or a multiple of this time period. Usually, there is no available data in advance regarding the load cycle, so it is beneficial if the recording segments utilized for the actual analyses can be freely specified.

PRECISION - ALGORITHMS AND ASSESSMENT

The recording precision, looked at over the overall measurement sector including evaluation, statistics and display, is subject to influences of various errors. The analysis of the voltage quality is, due to the frequency range in which the different impacts happen, only feasible by utilizing few measurement functions. Each recording function is itself subject to different limitations. The harmonics assessment is, band-fixed by the sampling frequency and the window end from which the recorded quantities are taken has an effect on the recorded finding. If the harmonics level in a data block being assessed varies fast, the final measurement will present great

deviations. This especially impacts current recordings, such as current recordings on arc furnaces. To get precise recordings the harmonic magnitude at a window of 160 ms or 200 ms has to be almost fixed for this time period. Disruption impacts happen when recording flicker if great voltage variations or voltage sags or voltage interruptions happen, because these cannot be showed by the flicker meter algorithm. It is suitable to minimize influences to ease assessment. This means that expressing in the amplitude of the recording resolution is adequate for processing recording findings in the statistics functions. Therefore, at a recording resolution of 0.1% of the nominal value, subdivision has also to be made with categories of this amplitude.

INSTRUMENT AND ISOLATING TRANSFORMERS, CURRENT CLAMP

The desired or needed recording precision is dependent on the purpose of the recording. The highest recording precision is needed if the reasonable compatibility levels found from an analysis of the recording findings are utilized as reference figures. In these cases, where consequences related with costs for the power supply company or customer may be deduced from the recordings, the recording devices used have to comply with a predetermined precision range. Moreover, in these situations the metrological limit conditions and methodologies of assessment have to follow the specified models, which guarantee same treatment and reproducible recording findings. For this reason, the regulations for the design of recording devices for the measurement and analysis of system disruptions define the vital features which impact the recording results. The block diagram of the measurement instrument to be considered is shown in Figure 19.

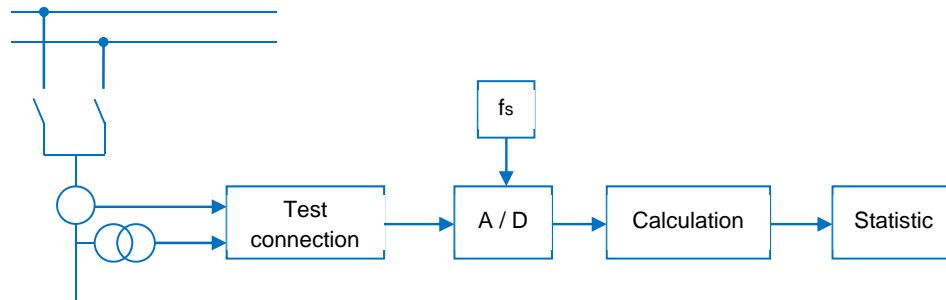

Figure 19. Overall arrangement of a recording line

Special care has to be paid to recording precision where the recordings are taken via

measuring transformers.

When recording the instant quantities which are analyzed in the time range, the sampling frequency, magnitude resolution, linearity and bandwidth are the key features. This is also applicable to harmonics recording devices. Certainly, the type of windows for the recorded quantities and the block length of recorded information which has to be utilized to check the harmonics values have a decisive impact on the recording results. The block length is especially important when recording harmonic levels which are not time constant, and not only impact the precision of the absolute value of the harmonics, but also has a considerable impact on the angular precision. The following requirements should be applied to the operation of 'standard compliant' recording of harmonics EN 61000-4-7.

- The assessment interval has to be matched to the device application.
- The recording precision has to be sufficiently high (class A for test bay recordings, class A or B for field recordings).
- The angular error has to be less than ± 5 or less than $h \times 1$ (h is the harmonic order).

USE AND CONNECTION OF MEASURING INSTRUMENTS

Low voltage system

In a low voltage electrical system the connection of recording devices is typically straightforward. The voltages can be assessed without the use of measuring transformers. The current can typically be recorded without problems using current clamps. The disturbing impact of unknown transmission functions is therefore prevented. When current clamps are applied it is also mandatory to disconnect any current transformer circuits. Figure 20 presents the potential recording and load arrangements in a low voltage electrical system. The recording system is well suited for recording harmonics and flicker. The line-to-ground voltage and line currents can be set in a direct relationship to each other. The line-to-ground voltages are the recorded variables suited for flicker recording because the lamp is also supplied via the line-to-ground voltage.

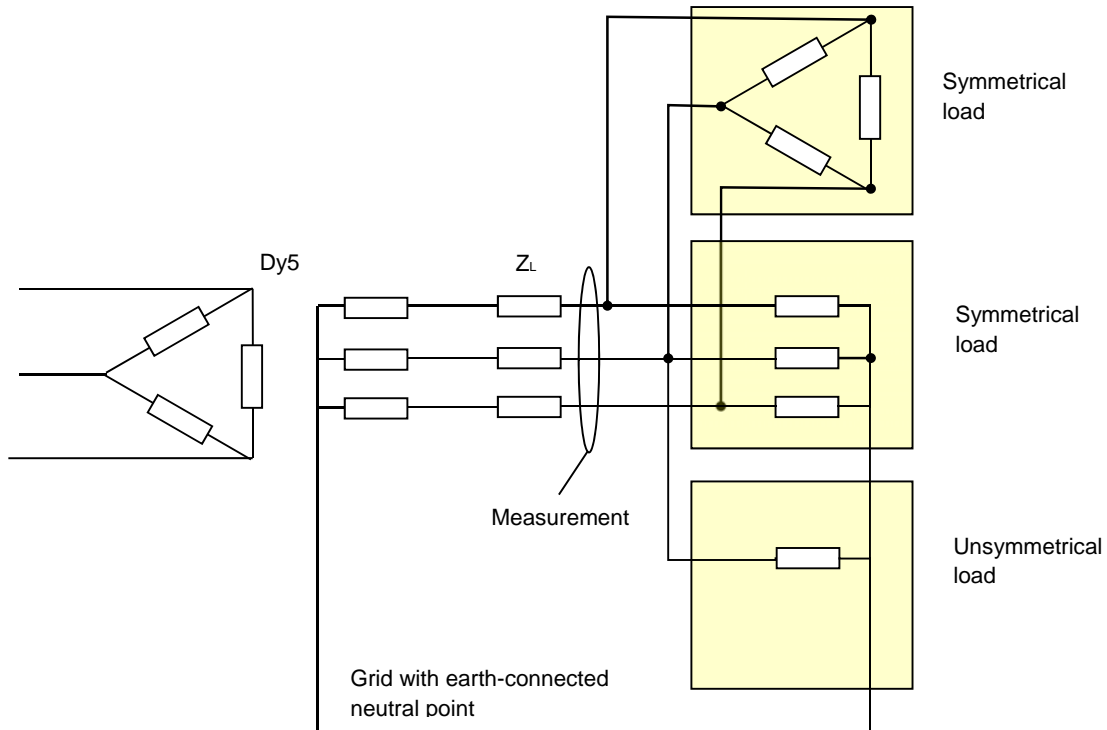

Figure 20. Recording arrangement in a low voltage system (TN-System)

Medium and high voltage systems

Recordings in medium and high voltage electrical systems can only be made through measuring transformers. The fitting of particular instrument transformers with known transmission functions is not feasible in the majority of cases of all recordings. The possible recording and load arrangements are presented in Figure 21.

The transmission function does not play a major role in the evaluation of the recordings of flicker. In contrast to the arrangement of measuring instruments in low voltage systems, the connection of the recording inputs in medium and high voltage systems can no longer be freely selected.

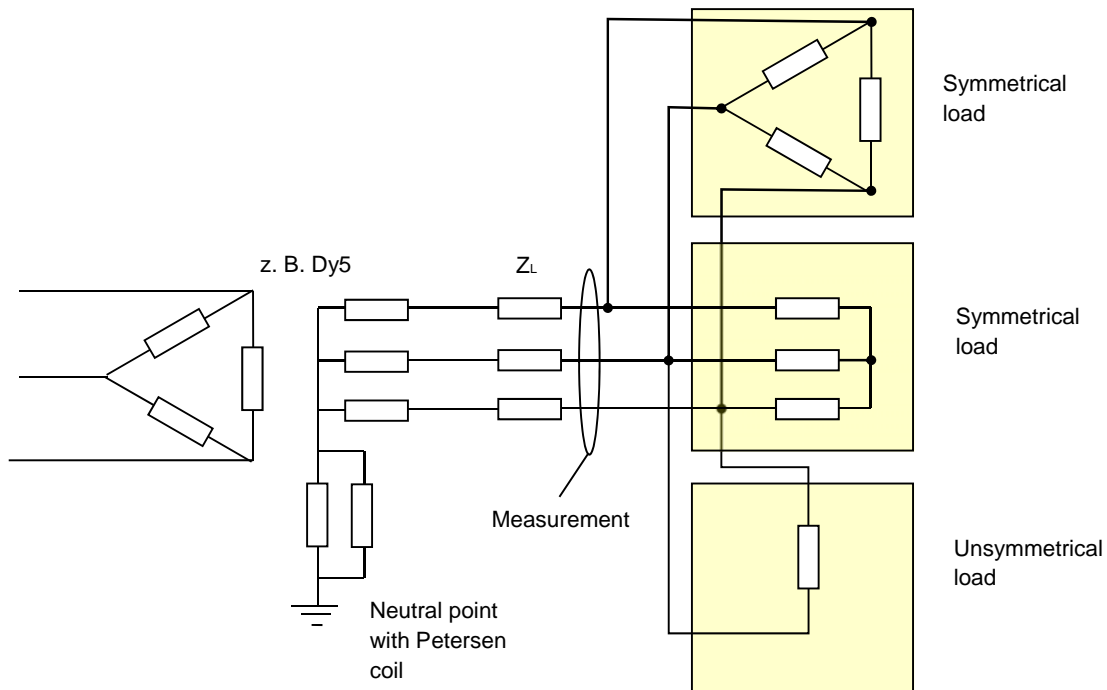

Figure 21. Recording arrangement in a medium voltage system

Depending on the structure of the transformer panels, the different arrangement may arise in these situations as presented in Figure 22. Completely-instrumented transformer panels with three voltage and three current transformers are rare in medium voltage electrical systems. For the recording of current, it is of small importance whether two or three current transformers are available. A missing current can be figured out by 'calculation' from two recorded currents. This can also be accomplished on the recording device by a suitable connecting circuit. The situation is more complex when recording the voltage. It is worthy, when measuring harmonics, to record the line-to-ground voltage as well as the line currents. In this way, data which can be measured on the angular relationships between the harmonic voltages and the harmonic currents is also obtained. It is practical to change the line-to-line voltages to line-to-ground voltages via an artificial neutral point. Nevertheless, this matches to the real conditions only if the three-phase electrical system does not have a zero sequence system. Moreover, the artificial neutral point heads to a compensation of the harmonics of an order relating to a multiple of three. The line-to-line voltages are of concern when recording flicker in MV electrical systems. Zero line-sequence occurrences have no implication with respect to the supply of the loads in medium voltage electrical systems. It is especially important that the line-to-line voltages should be recorded in

medium voltage electrical systems with ground-fault compensation because then any change in the zero sequence voltage shows up in the measurement result. Any variation in the electrical system can in this case lead to variations in the zero sequence system.

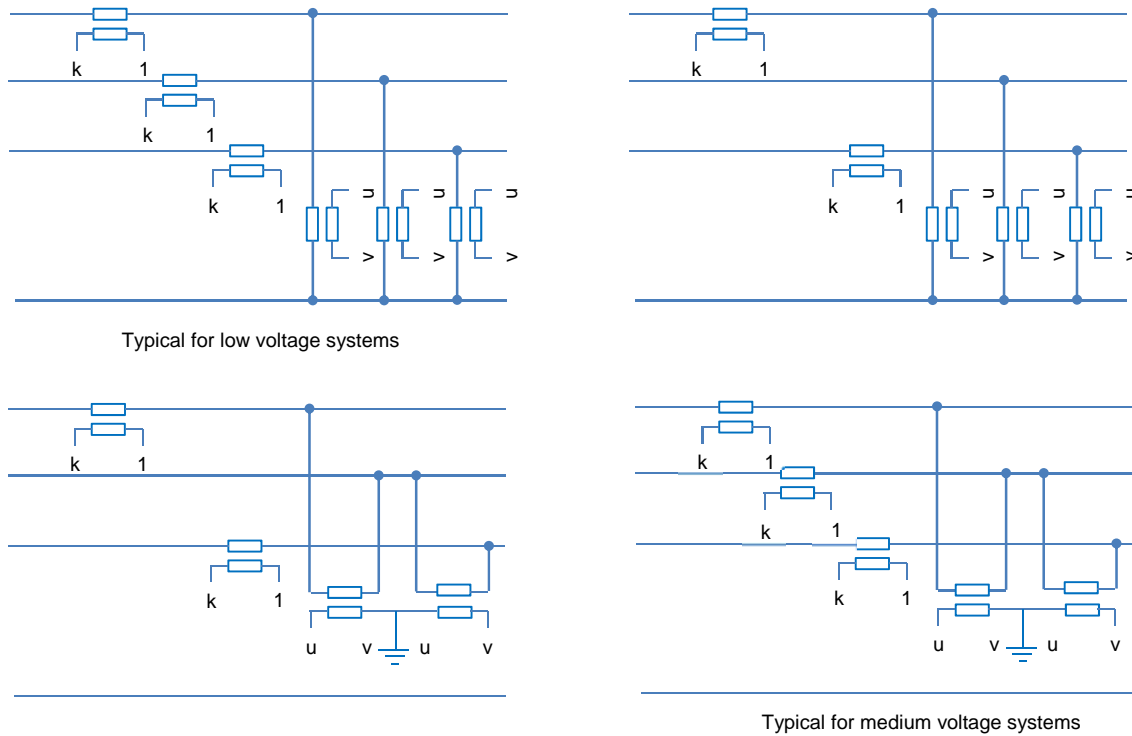

Figure 22. CT and VT arrangements in low and medium voltage systems

STANDARDIZATION

Standards specify binding rules for different aspects of the recording of system disruptions or voltage quality. The regulations cover the compatibility levels for voltage variations, unbalance and harmonics, and precise the recording and evaluation methodologies. Increasingly, the standard regulations no longer mention the voltage levels to be set, but instead precise groups of emitted interference which are allowable for particular items of devices or groups of devices. This consideration also has a favorable impact with regard to the metrological evaluation of recordings because an adequate differentiation can be made between cause and effect.

EN 61000-4-7 (VDE 0847 part 4-7) applies for the measurement of harmonics. This standard specifies the minimum requirements for instruments for measuring harmonics. It contains recommendations on methods of calculation, on the measurement range and on the statistical calculations. It also specifies measuring parameters and accuracy requirements. The accuracy requirements given in section 5.4.2 are taken from this standard. Instruments for measuring flicker are described in EN 60868 (VDE 0846). This standard contains the possible measuring methods and algorithms for the measurement of flicker. Test sequences which stipulate the measuring accuracy are also given.

FEATURES OF RECORDING INSTRUMENTS

Despite the characteristics which a recording device for the recording of the features of the voltage quality must have mentioned in regulations, there is still some degree of tolerance left for the design of recording devices. The features which are specifically needed depend to a great degree on the intended application of the recording devices.

These objectives can be varied:

- Evaluation of voltage quality,
- Compiling harmonics register,
- Decision of basic values for computations,
- Performance of comparison recordings,
- Conclusion of emitted interference,
- Evaluation of the causes of interference,
- Determining and evaluating countermeasures,
- Design and layout of electrical equipment.

If some of the features of recording devices are considered, it can be noted that their importance changes depending on the reason of the recording.

Recording inputs - with respect to the recording inputs, an appropriate design of the recording ranges is crucial, in addition to the number of channels of the voltage and current recording inputs. For recording in electrical power supply systems, the value ranges are spread as presented in Table 2. Recording devices utilized in electrical power supply systems must have a sufficiently high overload resistance, so that they

do not get damaged in the case of a system failure. Any number of recording channels can be found on the different recording devices. Four voltage and four current recording channels are sufficient. This allows a three-line electrical system to be totally recorded and it is still feasible to include the zero sequence system in the recordings in the low voltage system. Three recording channels for voltage and current are still appropriate, although a longer recording time period is needed for extra assessment of the zero sequence system. Devices with only one channel for current or voltage are limited. When only the current or the voltage can be recorded at one time this makes it challenging in many situations to assess the relationship between cause and effect.

Table 2. Recording inputs

Voltage	100/ $\sqrt{3}$ V	Recording range factor 1.4
	100 V	Recording range factor 1.4
	230 V	Recording range factor 1.4
	400 V	Recording range factor 1.4
Other measurement ranges via transformers or scalars		
Current	1 A	Recording range factor 2
	5 A	Recording range factor 2
Other recording ranges via intermediate transformers		

Recording functions - A consideration of suitable recording functions leads to the finding that, in addition to the harmonics analyzer and flicker meter as particular recording functions, an oscilloscope function delivers useful services. Because particular effects apply to only one section of a system period it could be pointed out with the first-named recording functions that an accurate recording or assessment is not practical for machine start-ups or commutation processes. If these conditions are extended to characteristics which happen for durations of between only a few periods and a few seconds, the transient recorder is in many situations the only device for the more accurate assessment of particular phenomena.

Bandwidth - The bandwidth of the recording devices depends on the application. According to the standard (EN 61000-4-7; EN 60868), it can be noted that harmonics analyzers must have a minimum bandwidth of 2.0 kHz. These devices can then record harmonics up to the 40th order. A bandwidth of 1.25 kHz is enough for many checks.

However, harmonics of the 25th order can be measured. For many recordings which extend into the area of disruption assessment and fault diagnosing it is best to have the greatest possible bandwidth. Devices with a 2.5 kHz or 3.0 kHz bandwidth, which can then record the harmonic elements up to the 50th or 60th order, usually give interesting additional data. A flicker meter does not need such a great bandwidth. In this situation values of 0.4 kHz to 1.2 kHz are sufficient, depending on the sampling frequency. Nevertheless, if the devices are equipped with the functionality of an oscilloscope or transient recorder, the bandwidth has to be as large as possible. If, for example, commutation oscillation with an oscillation frequency of 4 kHz is checked, this signal characteristic can be discovered even at a sampling frequency of 8 kHz, but for a clear picture a sampling frequency of around 40 kHz is required (ten times the signal frequency).

Measurement time period - For recordings of voltage quality and system disruptions in electrical power systems of the public supply system it can be presumed that an overall recording period with a duration of one week will be utilized. Recordings in industrial systems or recordings which are defined by a developed recording schedule, whereby, for instance, particular system states can also be adequately set, need considerably shorter recording periods.

Data recording - Data recording for long-term recordings must in most situations be completed with an averaging interval of 10 minutes, in order to ensure standard compliance. If the dynamics of the recorded signals are of interest, a shorter averaging interval is practical. At an interval of one minute, 1440 recorded values are collected over a 24 hour period. This implies that a recording covering one week consists of 11520 measuring intervals. The recording devices and the corresponding assessment program should have adequate capacity for these quantities. A very short recording interval is crucial for particular investigations. This should just be seconds.

CATEGORIZATION OF POWER QUALITY RECORDING INSTRUMENTS

Class	Applications
Class A	Used when precise evaluations are needed, for instance, for contractual usages that may need resolving disputes, checking compliance with regulations, etc. The complex recording methodologies and processes are described such as the time-clock precision, RMS value computation method and information processing methodology, etc.
Class S	Used for qualitative studies, trouble-shooting use and other applications where uncertainty is not needed.
Class B	Used for statistical evaluations and contractual projects where there are no conflicts.

PERFORMANCE OF RECORDINGS

Recordings are typically taken for different reasons. The first step in the preparation of a recording is to determine the aim of the recording. The question ‘What is to be accomplished?’ has to be answered. The next step is selecting the recording site and determining the recording devices. When the recording site and recording devices have been established, aspects of the connection of the recording devices must be considered. Especially where recordings are to be taken over a long time period, the recording devices should be placed in order to introduce the least disturbance. In switchyards, especially in customer electrical systems, this may not be so simple. The installed recording set up must also be properly protected against unauthorized access.

POWER QUALITY EVALUATIONS PROCESSES

Hints and practical steps for describing the cause of power quality issues are:

1. Show the trend of voltage and current at the receptacle

If the voltage decreases during the increase of current usage in a building, the reason

is believed to come from inside the building. However, if both the voltage and current decrease, the reason is assigned to devices or anomaly outside the building. It is vital to find out where to measure as well as to measure the current itself.

2. Verify the power trend

Overloaded devices are usually the cause of problem. By understanding the power trend, it is simpler to define the actual devices or location that is making the problems.

3. Check WHEN the event occurred

Devices that are in service or restarting at the time event is recorded can be the cause of the issue. By precisely describing what time the event happened and when an issue settled, it can be simpler to understand which device or location could have made the issue.

4. Check for heat and bad sounds produced by the equipment

Overheating or bad sounds generated by the motor, transformer or cable are signs that there are issues due to overload or harmonics.

Step 1: Purpose

(1) Survey power quality - Go to Step 3

- Periodic power quality statistics assessment
- Assessment before and after installing new devices
- Load assessment
- Predictive maintenance

(2) Troubleshooting - Go to Step 2

- Determining the cause of malfunction/damage to device
- Consider countermeasures for power supply issues

Step 2: Understanding the trouble (where to measure)

(1) What kind of trouble has happened?

- Main electronic devices

Large copy machines, UPS, elevator, air compressor, air-conditioning compressor, battery charger, cooling equipment, air handler, timer controlled lighting, variable frequency drive, etc.

- Distribution

Damage or decay on conduit (electric cable pipe),

Overheat, noise or oil leakage on transformer,

Opening or overheat on circuit breaker, etc.

(2) When did the problem happen?

- Always, Periodic, Intermittent
- Specific time or date

(3) Where and What should be recorded?

- Voltage, Current, (Power) - Always suggested
- The cause can be determined far easier by evaluating the voltage and current patterns during the time the problem happened
- Assess numerous locations simultaneously – makes it simpler to identify the cause of the issue
- Circuits in the transmission station (power utilities only)
- Receptacle (high voltage, low voltage)
- Distribution panel
- Outlet or power supply terminal for electronic devices

(4) What is the assumed reason?

- Voltage issue

RMS value variations, Waveform distortion, Transient overvoltage, High-order harmonic

- Current problem leakage current, Inrush current

Step 3: Know the Recording Site

Gather data about the recording site, including:

- Circuit arrangement
- Nominal supply voltage
- Frequency
- Requirement of neutral line recording and DC voltage recording
- Current capacity
- Other data about facilities, including:

Existence of other power quality sensing devices, main electronic equipment running cycle, newly introduced or removed device, distribution network design, etc.

Step 4: Record

- Record using a power quality analyzer.
- Wiring check
- Analyzer checks connection of the recording circuit, and provides confirmation of correct connection.